

Description

The Wesco Spartan III Convertible Hand Truck is specifically designed to convert between a 2-wheel vertical, 2-wheel 45° position or a 4 wheel platform truck position. It features a recessed folding nose, a cast aluminum noseplate and 10" pneumatic wheels.

This product is distributed by:

Wesco Industrial Products, LLC
1250 Welsh Road
North Wales, PA 19454
Tel: 215-699-7031 Fax: 215-699-3836

Contact the factory for parts information and ordering.
Visit us on the web at www.wescomfg.com

Unpacking

When unpacking the Wesco Product, check carefully for shipping damage and missing parts. If damage has occurred or any parts are missing, file a claim with the delivering carrier within 24 hours and notify the dealer from whom the unit was purchased.

Warranty Repairs

If the unit does not work properly, contact your dealer or the factory (215-699-7031) for units less than 90 days old.

Non-Warranty Service

If units are older than 90 days, repairs can be made easily on site with factory supplied parts.

NOTE: Do not send units to the factory for service without first obtaining a "Return Merchandise Authorization" (RMA) number from the customer service department. We will not be responsible for merchandise returned without proper authorization.

General Safety Information

The Wesco Spartan III Convertible Hand Trucks are designed for specific functions. To insure proper use, the following instructions must be adhered to:

- (1) DO NOT overload the Truck beyond the rated capacity of the unit, Maximum capacity – 2 Wheel 500 lbs.
– 4 Wheel 750 lbs.
- (2) Stack all loads centered on truck.
- (3) DO NOT move a load stacked higher than the body of the truck
- (4) Keep hands and feet away from the bottom of the load.
- (5) Tilt loaded truck in 2-wheel vertical with caution, making sure to maintain control.
- (6) Use extreme caution when moving on uneven floors.
- (7) DO NOT use on stairs.
- (8) DO NOT convert a loaded truck to other positions. Only unloaded trucks can be converted safely between positions.



Figure 1

LIMITED WARRANTY

WESCO INDUSTRIAL PRODUCTS (WESCO) warrants to the purchaser of this product for a period of ninety (90) days from the date of purchase that this product shall be free of defects in material and/or workmanship, as follows:

1. WESCO will supply, at no charge, new or rebuilt replacements for any part that fails through a defect in material and/or workmanship during the warranty period. To obtain warranty service, you must deliver the product prepaid, to the WESCO factory.

2. This warranty does not cover any product or product part which has been subject to accident, misuse, abuse or negligence. WESCO shall only be liable under this warranty if the product is used the manner intended by the manufacturer as specified in the written instructions furnished with this product.

REPAIR OR REPLACEMENT AS PROVIDED UNDER THIS WARRANTY IS THE EXCLUSIVE REMEDY OF THE PURCHASER. ANY EXPRESS WARRANTY NOT PROVIDED IN THIS WARRANTY DOCUMENT, AND ANY REMEDY FOR BREACH OF CONTRACT THAT, BUT FOR THIS PROVISION, MIGHT ARISE BY IMPLICATION OR OPERATION OF LAW, IS HEREBY EXCLUDED AND DISCLAIMED. UNDER NO CIRCUMSTANCES SHALL WESCO BE LIABLE TO PURCHASER OR ANY OTHER PERSON FOR ANY INCIDENTAL OR CONSEQUENTIAL DAMAGES, WHETHER ARISING OUT OF BREACH OF WARRANTY, EXPRESS OR IMPLIED, A BREACH OF CONTRACT OR OTHERWISE. EXCEPT TO THE EXTENT PROHIBITED BY APPLICABLE LAW, ANY IMPLIED WARRANTY OF MERCHANTABILITY AND FITNESS FOR ANY PARTICULAR PURPOSE ARE EXPRESSLY LIMITED IN DURATION TO THE DURATION OF THIS LIMITED WARRANTY.

Some states do not allow the exclusion or limitation of incidental or consequential damages, or allow limitations on how long any implied warranty lasts, so the above limitations may not apply to you. This warranty gives you specific legal rights, and you may also have other rights which vary from state to state.

Assembly Instructions

- (1) Assemble with noseplate, right axle support, left axle support, and inside reinforcements to frame with 8 mm bolts as shown. Be sure to insert reinforcements between noseplate and frame before inserting screws. Thread nylock nuts onto 8 mm bolts and tighten.
- (2) Insert axle through axle supports, using the higher of two hole positions.
- (3) On inside axle holes insert spring pins through axle so the pins rest in the slots of axle supports to prevent rotation.
- (4) Slide washer on each end of axle, then wheels and then another washer.
- (5) Insert cotter pin through hole at each end of axle and bend one leg.
- (6) Slide handle onto back side of frame, insert bolts and tighten.
- (7) Check air pressure in tires, maintain (30) PSI.

Replacement Parts List

Items Identified in Figure 2

Item	Part No.	Description
1	151508	Right Hand Axle Box
2	151509	Left Hand Axle Box
3	151527	Noseplate
4	151551	Pneumatic Tire
5	270397	Swivel Caster
6	270398	Handle w/ Rubber Grip & Hardware
7	270394	Retaining "L" Latch
8	270419	Folding Nose
9	270420	Support Bar

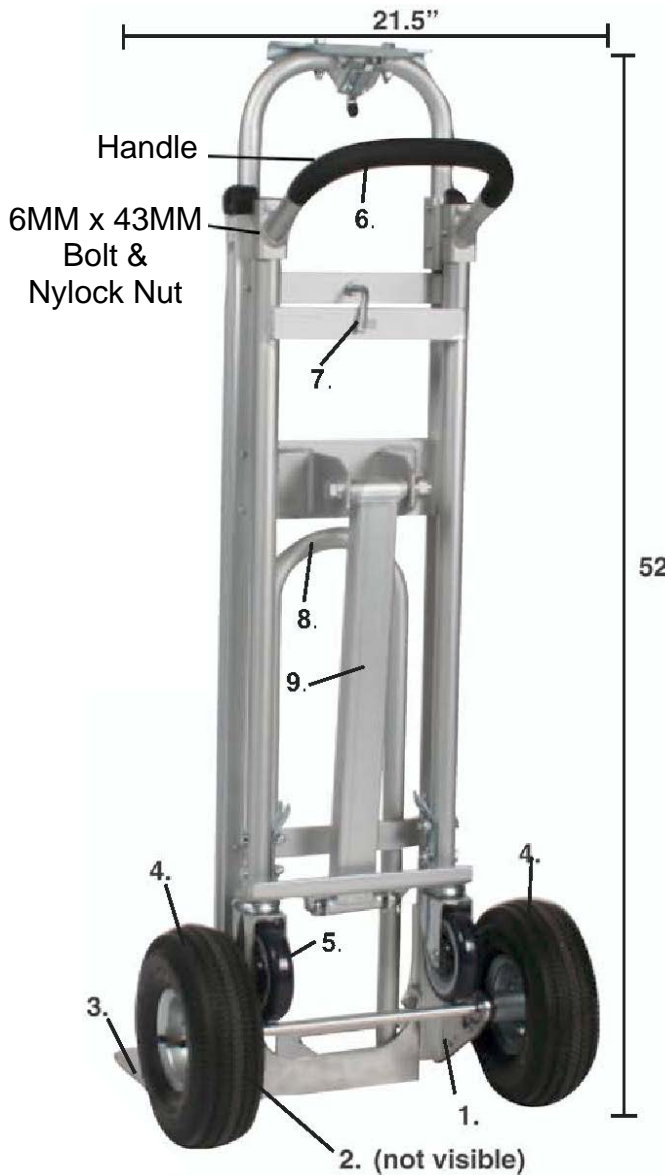

Figure 2

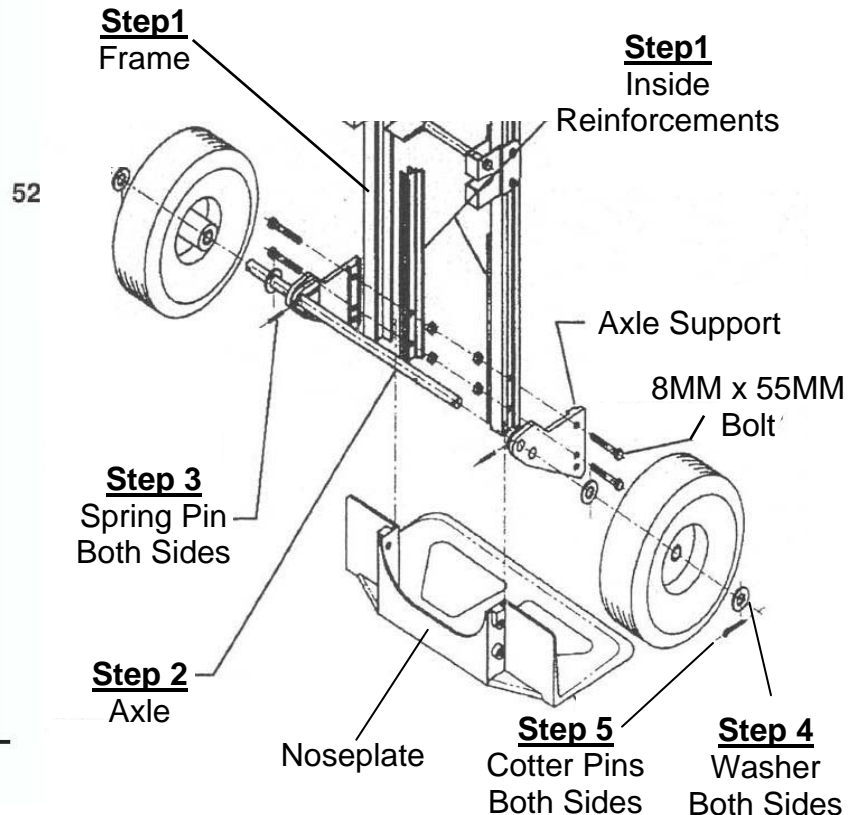

Figure 3